



Black Cabinet with Stand



Gray Cabinet with Stand



VESA Mount



Panel Mount



Chassis

## 15" Industrial Monitors Available in Four Configurations and Backed by a 2-Year Warranty

	Cabinet Color	With Stand	VESA Mount	Panel Mount IP65 Supported	Chassis
FDX1501	Black	•	•	•	•
	Gray	•	•		
FDX1501T	Black	•	•	•	•
	Gray	•	•		

### Available in Four Configurations

To meet the needs of different industrial environments, these monitors are available in four configurations: with a stand, VESA mount (no stand), panel mount, and chassis. For each configuration, a touch panel is optional for a total of eight variations.

### High Brightness Display for Better Visibility

The maximum brightness of 400 cd/m<sup>2</sup> (320 cd/m<sup>2</sup> for the FDX1501T) ensures excellent screen visibility in bright ambient environments.

### Durable Construction

To prevent dust or liquids from entering, the monitors do not contain any ventilation holes and there are no gaps around the perimeter of the control buttons.

### IP65 Rating for Panel Mount Configuration

The front panel of the panel mount configuration is IP65-rated meaning it can withstand dust ingress and is protected against low-pressure water jets. This durability ensures the monitor is ideal for deployment in factories.

## Mercury-Free, White LED Backlight

The LED backlight is very energy efficient, consuming a maximum of 19 watts of power at the maximum brightness setting of 400 cd/m<sup>2</sup>. Unlike a CCFL backlight, an LED backlight is mercury free so it will have minimal impact on the environment when it is disposed of.

## Low Brightness Preset

Four preset modes are included: EyeCare, sRGB, Text, and Custom. EyeCare mode uses the LED backlight to lower brightness to just 3 cd/m<sup>2</sup> while maintaining tonal display. This is convenient when using the monitors in a very dim ambient environment.

## Flexible Positioning

The monitors are built to operate in both standard horizontal positions and non-standard positions such as attached to a mounting device and tilted at an extreme angle. Furthermore, their internal circuitry is designed to withstand varying operating temperatures of different installation environments.

## Optimized Brightness with Auto EcoView

An Auto EcoView sensor on the front measures ambient light and adjusts the screen's brightness accordingly. Since the screen is never too bright, eye strain is reduced while power consumption is reduced.

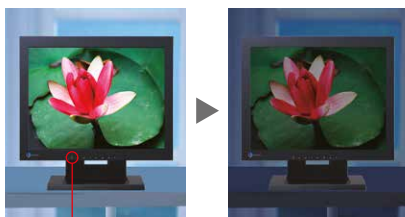

Auto EcoView

## Energy Efficiency Gauge

To encourage environmental consciousness while working, a user-activated gauge called "EcoView Index" indicates power and CO<sub>2</sub> reduction compared to using the monitor with the Auto EcoView function turned off.

## Zero Watts When Turned Off

Power consumption drops to just 1 watt in power save mode and when turned off via the main power switch no power is consumed at all.

## Analog and Digital PC Inputs

For connecting to PCs, all versions of both monitors come with D-Sub mini 15-pin analog and DVI-D 24-pin digital inputs.

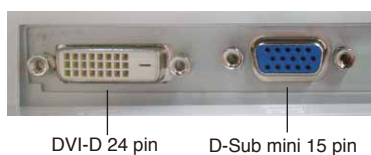

Monitor cable included  
(D-Sub mini 15 pin)

## Built-In Speakers

The standard and VESA mount versions are equipped with dual 0.5-watt speakers and headphone jacks.

## 24-Hours/Day, 2-Year Warranty

Both monitors come with a two-year warranty for continuous round-the-clock use.

## Wide Operating Temperature

The monitors operate in a temperature range of 0 – 50°C and relative humidity of 20 – 90%.

## 2 Color Variations



## Touch Screen LCD Monitor FDX1501T

- 10 million touches minimum
- Resistant to liquids and dust
- Accepts touch input from bare and gloved hands

### Touch Panel Specifications

Touch Panel Type	Analog resistive
Touch Life	10 million (min.)
Communication Protocol	USB 2.0
Compatible OSES	Windows 7 (32-bit)* Windows Vista (32-bit) Windows XP (32-bit) Windows 2000

\*Windows 7 (32-bit) driver downloadable from [www.eizo.com](http://www.eizo.com).





Model Name	With Stand	VESA Mount	Panel Mount	Chassis
FDX1501	5.7 kg	3.3 kg	3.8 kg	2.7 kg
FDX1501T	6.1 kg	3.7 kg	3.9 kg	3.4 kg
Hole Spacing (VESA)	100 mm x 100 mm			
Operating Temperature	0 - 50°C, 20 - 90% R.H. (No condensation)			

### Dimensions (mm)

#### With Stand

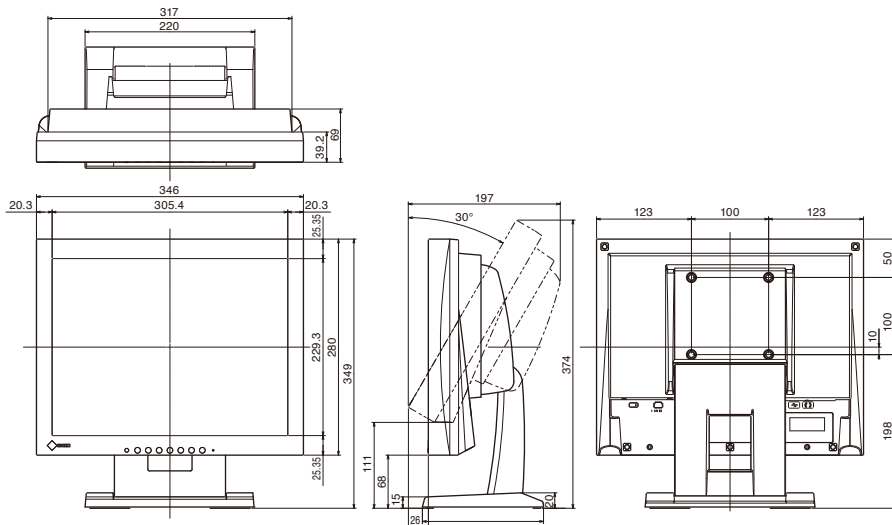

#### VESA Mount

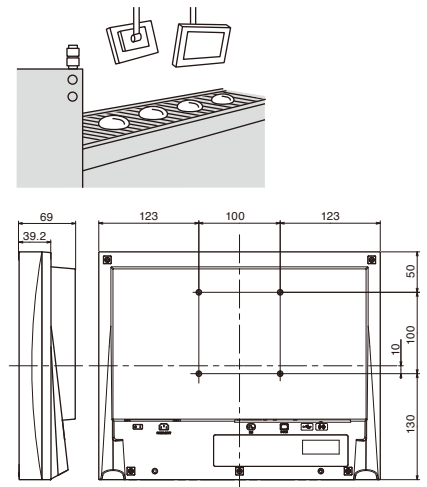

#### Panel Mount

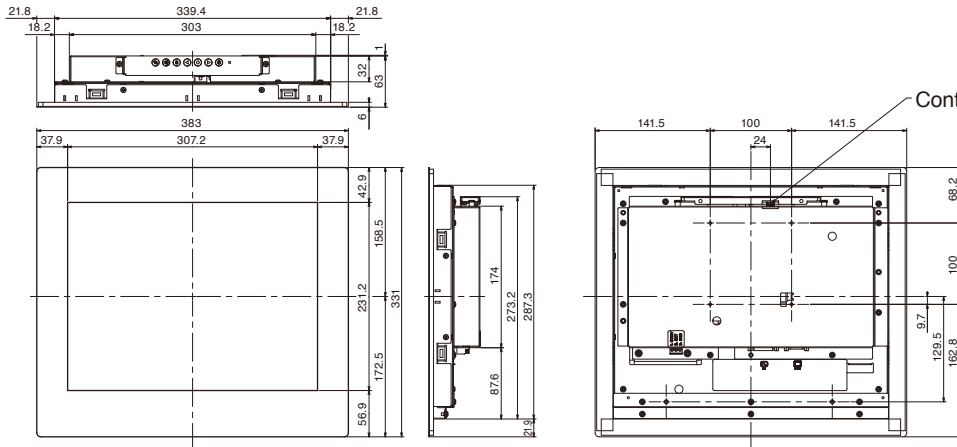

Control button / extension connector

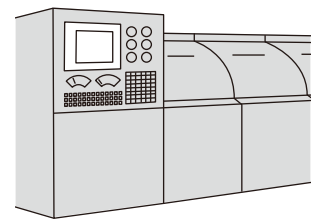

#### Chassis \* () indicates FDX1501T

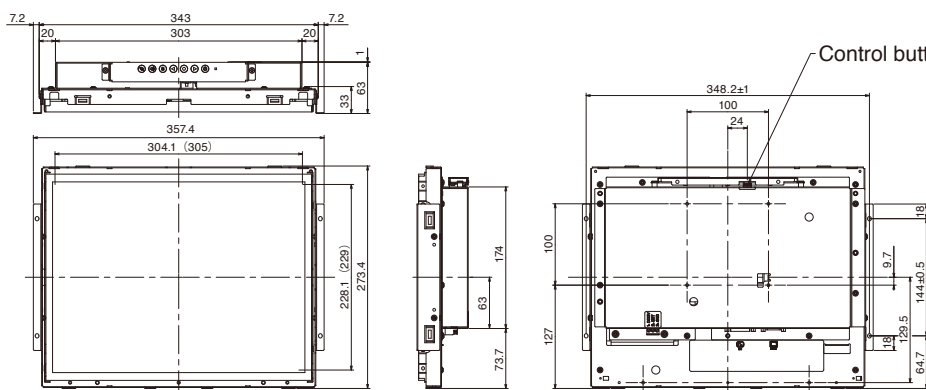

Control button / extension connector

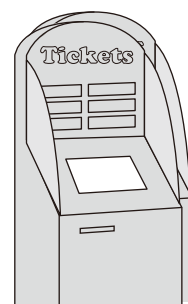

## SPECIFICATIONS

	Without Touch Panel FDX1501	With Touch Panel FDX1501T
<b>Model Variations</b>	With Stand, Without Stand, Panel Mount, Chassis	With Stand, Without Stand, Panel Mount, Chassis
<b>Cabinet Color</b>	Gray, Black	Gray, Black
<b>Panel</b>	TN	TN
<b>Size</b>	15" / 38 cm (380 mm diagonal)	15" / 38 cm (380 mm diagonal)
<b>Native Resolution</b>	1024 x 768 (4:3 aspect ratio)	1024 x 768 (4:3 aspect ratio)
<b>Display Size (H x V)</b>	304.1 x 228 mm	304.1 x 228 mm
<b>Pixel Pitch</b>	0.297 x 0.297 mm	0.297 x 0.297 mm
<b>Display Colors</b>	16.2 million	16.2 million
<b>Viewing Angles (H / V, typical)</b>	160°, 140°	160°, 140°
<b>Brightness (typical)</b>	400 cd/m <sup>2</sup>	320 cd/m <sup>2</sup>
<b>Contrast Ratio (typical)</b>	700:1	700:1
<b>Response Time (typical)</b>	8 ms (Black-white-black)	8 ms (Black-white-black)
<b>Input Terminals</b>	DVI-D 24 pin x 1 (with HDCP), D-Sub mini 15 pin x 1	DVI-D 24 pin x 1 (with HDCP), D-Sub mini 15 pin x 1
<b>Digital Scanning Frequency (H / V)</b>	31 - 49 kHz, 59 - 61 Hz (VGA Text: 69 - 71 Hz)	31 - 49 kHz, 59 - 61 Hz (VGA Text: 69 - 71 Hz)
<b>Analog Scanning Frequency (H / V)</b>	24.8 - 60.1 kHz, 55 - 75 kHz	24.8 - 60.1 kHz, 55 - 75 kHz
<b>Power Requirements</b>	With Stand Model, VESA Mount Model: AC 100 - 120 V / 200 - 240 V, 50 / 60 Hz Panel Mount Model, Chassis Mount Model: DC 12 V	With Stand Model, VESA Mount Model: AC 100 - 120 V / 200 - 240 V, 50 / 60 Hz Panel Mount Model, Chassis Mount Model: DC 12 V
<b>Maximum Power Consumption</b>	With Stand Model, VESA Mount Model: 19 W Panel Mount Model, Chassis Mount Model: 12 W	With Stand Model, VESA Mount Model: 19 W Panel Mount Model, Chassis Mount Model: 12 W
<b>Power Save Mode</b>	Less than 1.0 W	Less than 1.0 W
<b>Power Management</b>	Off Timer	Off Timer
<b>Others</b>	Screen Adjustment (Clock, Phase, Position, Range (Auto), Smoothing (5 stages), Color Adjustment (Brightness, Contrast, Gamma, Temperature, Gain, Reset, Color Mode), Signal Switching, Power Indicator, Product Information (name, serial number, resolution, operating time, etc.), OSD Menu Position, Reset	Screen Adjustment (Clock, Phase, Position, Range (Auto), Smoothing (5 stages), Color Adjustment (Brightness, Contrast, Gamma, Temperature, Gain, Reset, Color Mode), Signal Switching, Power Indicator, Product Information (name, serial number, resolution, operating time, etc.), OSD Menu Position, Reset
<b>Dimensions</b>	With Stand: 346 x 349 x 157 mm Without Stand: 346 x 280 x 69 mm Panel Mount: 383 x 331 x 63 mm Chassis: 357.4 x 273.4 x 63 mm	With Stand: 346 x 349 x 157 mm Without Stand: 346 x 280 x 69 mm Panel Mount: 383 x 331 x 63 mm Chassis: 357.4 x 273.4 x 63 mm
<b>Net Weight</b>	With Stand: 5.7 kg Without Stand: 3.3 kg Panel Mount: 3.8 kg Chassis: 2.7 kg	With Stand: 6.1 kg Without Stand: 3.7 kg Panel Mount: 3.9 kg Chassis: 3.4 kg
<b>Tilt</b>	30° Up, 0° Down	30° Up, 0° Down
<b>Certifications &amp; Standard</b>	CE, RoHS, WEEE With Stand, Free Mount Model: cTUVus, c-Tick / CB / FCC-B / Canadian ICES-003-B	CE, RoHS, WEEE With Stand, Free Mount Model: cTUVus, c-Tick / CB / FCC-B / Canadian ICES-003-B
<b>Supplied Accessories</b>	Signal cable (D-Sub - D-Sub), setup manual, CD-ROM (PDF user's manual), screws for mount option, clasper, warranty card, audio cable, (stand and free mount options only), clasp (panel mount option only)	Signal cable (D-Sub - D-Sub), USB cable, setup manual, CD-ROM (PDF user's manual, touch panel driver), screws for mount option, clasper, warranty card, audio cable, (stand and free mount options only), clasp (panel mount option only)
<b>Warranty</b>	Two Years	Two Years

### Touch Panel

Type	-	Analog resistive
<b>Communication Protocol</b>	-	USB 2.0
<b>Touch Life</b>	-	10 million touches (minimum)
<b>Compatible OS</b>	-	Windows 7 (32-bit) / Vista (32-bit) / XP (32-bit) / 2000

### Panel mount version installation requirements

Applicable to level installations only.

#### Panel aperture dimensions

(Unit: mm)

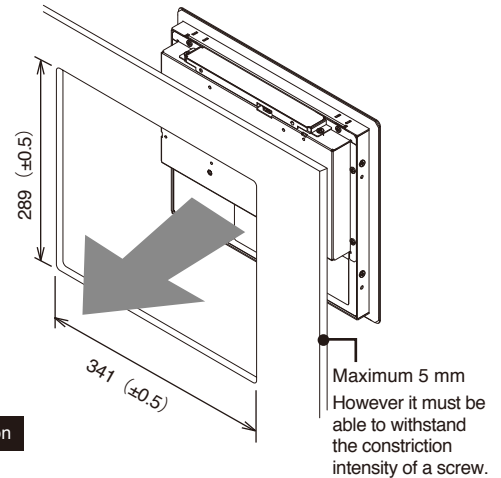

#### Panel Installation

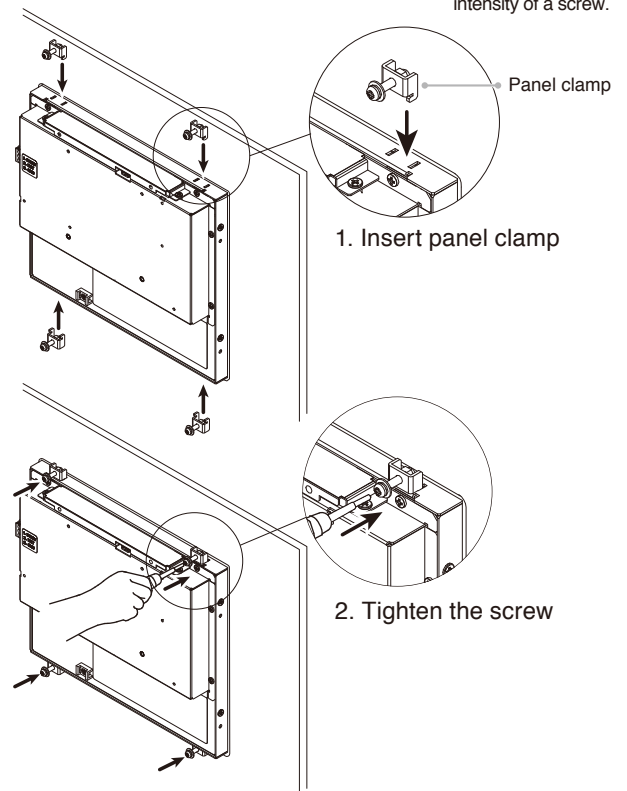

### DC Supply Terminal Block Connection Conditions (Panel Mount and Chassis Models)

Input Signal



Pin No.	Input Signal
1	DC12V
2*	DET
3	Ground

Power Supply

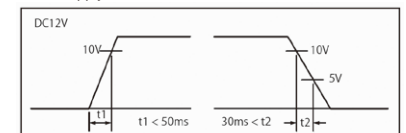

\* Do not use.



## EIZO NANA0 CORPORATION

153 Shimokashiwano, Hakusan, Ishikawa 924-8566 Japan

Phone +81-76-277-6792 Fax: +81-76-277-6793

www.eizo.com

© 2012 Eizo Nanao Corporation

All product names are trademarks or registered trademarks of their respective companies. DuraVision and EIZO are registered trademarks of Eizo Nanao Corporation. Specifications are subject to change without notice.