

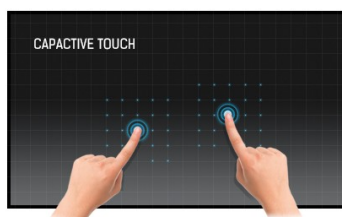

Open Frame PCAP 10 point touch screen equipped with a foam seal finish for seamless integration

The ProLite TF2215MC-B1 (21.5 inch) uses PCAP touch technology and is built into an eye-catching bezel with edge-to-edge glass. Thanks to a glass overlay covering the screen and a rugged bezel, it guarantees high durability and scratch-resistance, making it perfect for kiosk and high use public facing applications.

Equipped with a foam seal finish it supports seamless integration into kiosks and provides IP65 rating resulting in dust and water resistance from the front. Landscape, portrait and face-up orientation ensures flexible mounting possibilities in almost any installation. For ease of integration, the TF2215MC-B1 comes equipped with external mounting brackets making it an ideal solution for kiosk integrators, industrial environments, control rooms and interactive multimedia.



TOUCH TECHNOLOGY - CAPACITIVE

This technology uses a sensor-grid of micro-fine wires integrated into the glass that covers the screen. Touch is detected because electrical characteristics of the sensor grid change when human finger is placed on the glass. Thanks to the glass overlay this technology is highly durable, and the touch function remains unaffected even if the glass is scratched. It offers perfect picture performance and will work with human finger (also latex gloved) and stylus-pen.

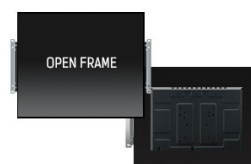

OPEN FRAME BRACKETS

This open frame monitor comes equipped with external mounting brackets. It guarantees easy installation and makes it an ideal solution for kiosk integrators and Instore Retail.

1. DISPLAY CHARACTERISTICS

DIAGONAL	21.5"; 54.6cm
ASPECT RATIO	16 : 9
PANEL	IPS LED
NATIVE RESOLUTION	1920 x 1080 (2.1 megapixel)
BRIGHTNESS	250 cd/m ² typical
BRIGHTNESS	215 cd/m ² with touch panel
CONTRAST	1000 : 1 with touch panel
RESPONSE TIME	14ms
VIEWING ZONE	horizontal/vertical: 178° / 178° ; right/left: 89° / 89° ; up/down: 89° / 89°
DISPLAY COLOUR	16.7 million

TOUCHTECHNOLOGY	projective capacitive, multi touch (10 compatible touch points - only with supported OS), activated by finger (with or without gloves - latex only) or stylus
TOUCH POINTS	10
GLASS HARDNESS	7H minimum
LIGHT TRANSMITTANCE	85%
DISPLAY AREA H X W	268.11 x 476.64 mm; 10.6" x 18.9"
PIXEL PITCH H X V	0.24795 x 0.24795 mm
HORIZONTAL SYNC	30 - 82kHz
VERTICAL SYNC	56 - 75Hz
SYNCHRONIZATION	Separate Sync

2. INTERFACES & CONNECTORS

ANALOG INPUT CONNECTOR	VGA
DIGITAL INPUT CONNECTOR	HDMI, DisplayPort
AUDIO OUT	MiniJack
CONTROLS	USB (touch)

3. FEATURES

PLUG & PLAY	VESA DDC2B™
CONTROLS	On-Screen-Display in 7 languages (EN, FR, DE, IT, ES, JP, Chinese) and 5 controls (Menu, Scroll up/ Brightness, Scroll down/ Contrast, Select, Power)
USER CONTROLS	contrast, brightness, auto adjust, H.position, V.position, H.size, fine, OSD H.position, OSD V.position, OSD timeout, reset, input select, OSD language, colour temperature
REGULATIONS	CE, CB, TÜV-Bauart, CU, cULus
VESA MOUNTING	100 x 100 mm
COLOUR	Black
ORIENTATION	landscape/ portrait/ face-up
BALL DROP TEST PROOF	yes
WATER AND DUST PROTECTION	IP65

4. ACCESSORIES

DRIVER	multi-touch: Windows 7/8/10 (HID compliant), single-touch: Vista, XP, CE, Mac (OSX), Linux
INCLUDED ACCESSORIES	AC adapter, power cable, HDMI signal cable, DisplayPort signal cable, USB cable, L-Bracket, remote control, Touch Panel Driver Disk (CD-ROM), quick start guide, safety guide

5. POWER MANAGEMENT

POWER SUPPLY	DC 12V
POWER SUPPLY UNIT	external

POWER USAGE	19 W typical; max. 1.2 W in Power management mode
POWER MANAGEMENT	VESA DPMS

6. DIMENSIONS & WEIGHT

DIMENSIONS W X H X D	315 x 519.9 x 42.5 mm
WEIGHT	4.4 kg

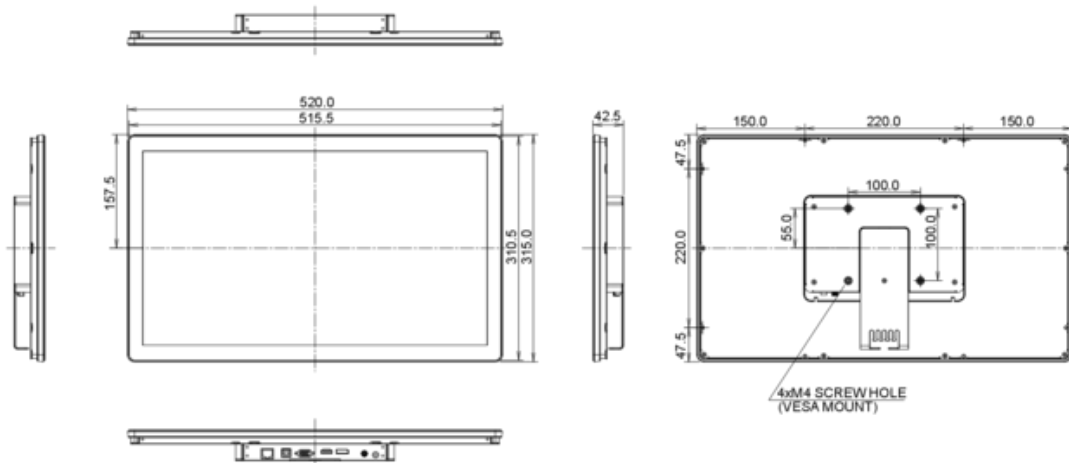

All trademarks and registered trademarks acknowledged. E & O E. Specification subject to change without notice. All LCD's comply with ISO-9241-307:2008 in connection with pixel defects.

© IIYAMA CORPORATION (). ALL RIGHTS RESERVED.