

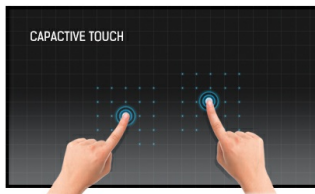

17" Open Frame 10pt touch monitor

The ProLite TF1734MC 17" multi touch screen is based on projective capacitive technology which thanks to a glass overlay covering the screen guarantees high durability, scratch-resistance and perfect picture performance. The touch function remains unaffected even if the glass is scratched. The screen is IP65 rated which means it is dust and water resistant. For ease of installation in any environment the ProLite TF1734MC comes equipped with external mounting brackets making it an ideal solution for kiosk integrators and Instore Retail.



Touch technology - Capacitive

This technology uses a sensor-grid of micro-fine wires integrated into the glass that covers the screen. Touch is detected because electrical characteristics of the sensor grid change when human finger is placed on the glass. Thanks to the glass overlay this technology is highly durable, and the touch function remains unaffected even if the glass is scratched. It offers perfect picture performance and will work with human finger (also latex gloved) and stylus-pen.



Open frame brackets

This open frame monitor comes equipped with external mounting brackets. It guarantees easy installation and makes it an ideal solution for kiosk integrators and Instore Retail.

01 DISPLAY CHARACTERISTICS

Design	Open Frame
Diagonal	17", 43cm
Panel	TN LED
Native resolution	1280 x 1024 (1.3 megapixel)
Aspect ratio	5:4
Brightness	250 cd/m ² typical
Brightness	225 cd/m ² with touch
Static contrast	1000:1 with touch
Light transmittance	90%
Response time	5ms
Viewing zone	horizontal/vertical: 170°/160°, right/left: 85°/85°, up/down: 80°/80°
Colour support	16.7mln (6bit + A-FRC)
Horizontal Sync	31,4 - 80KHz
Vertical Sync	50 - 75Hz
Viewable area W x H	338 x 270.5mm, 13.3 x 10.6"
Pixel pitch	0.264mm
Bezel colour and finish	black, matte

02 TOUCH

Touch technology	projective capacitive
Touch points	10 (HID, only with supported OS)
Touch method	stylus, finger, glove (latex)
Touch interface	USB
Supported operating systems	All iiyama monitors are Plug & Play and compatible with Windows and Linux. For details regarding the supported OS for the touch models, please refer to the driver instruction file available in the downloads section.

03 INTERFACES / CONNECTORS / CONTROLS

Analog signal input	VGA x1
Digital signal input	HDMI x1 DisplayPort x1
HDCP	yes

04 FEATURES

Impact testing	IP65 (front)
OSD key lock	yes

05 GENERAL

OSD languages	EN, DE, FR, ES, IT, CN, JP
Control buttons	Menu, Scroll up/ Brightness, Scroll down/ Contrast, Select, Power
User controls	contrast, brightness, auto adjust, H.position, V.position, H.size, Fine, OSD H.position, OSD V.position, OSD timeout, reset, input select, OSD language, colour temperature
Plug&Play	DDC2B

06 MECHANICAL

VESA mounting 100 x 100mm

07 ACCESSORIES INCLUDED

Guides	quick start guide, safety guide
Other	AC adapter, Touch Panel Driver Disk (CD-ROM), L-Bracket
Cable cover	yes

08 POWER MANAGEMENT

Power supply unit	external
Power supply	DC 12 V
Power usage	20W typical, 2W stand by

09 SUSTAINABILITY

Regulations CB, CE, TÜV-Bauart, CU, cULus

10 DIMENSIONS / WEIGHT

Product dimensions W x H x D 369 x 307 x 47.5mm

Weight (without box) 3.6kg

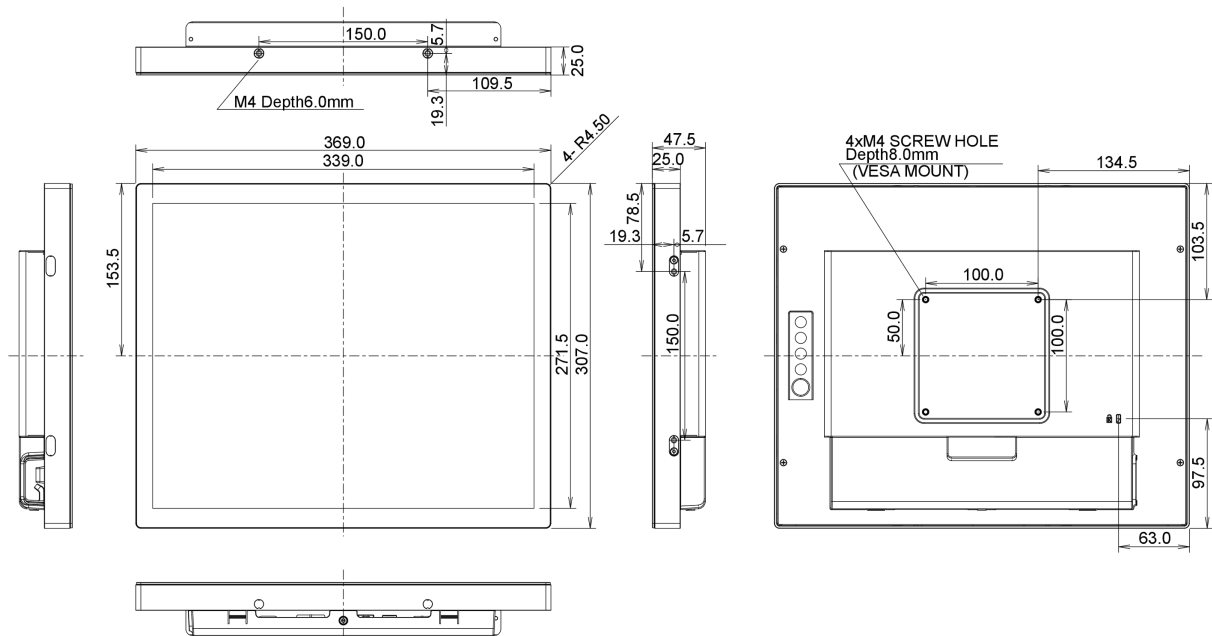

All trademarks and registered trademarks acknowledged. E & O E. Specification subject to change without notice. All LCD's comply with ISO-9241-307:2008 in connection with pixel defects.

© IYAMA CORPORATION. ALL RIGHTS RESERVED