



PN-80TH5 PN-70TH5

4K BIG PAD Interactive display solutions

www.sharp.eu

SHARP
Be Original.

Visibly better collaboration.



Easy to work with and a real boost to any working environment, the PN-80TH5/PN-70TH5 flagship 4K BIG PADs from Sharp bring collaboration and presentation to life.

A great presentation tool should have stunning visual capabilities and first-rate user experience. Naturally, this is what you can expect from Sharp. But with the **PN-80TH5/PN-70TH5** BIG PADs you can go much further. As our first 4K interactive displays our flagship BIG PADs are packed full of advantages that will help you transform any meeting into a vibrant, valuable discussion and ensure everyone is able to participate fully.



Whether you're dealing with mission critical, specialist professional applications, or huddles and discussions, the 4K 3840 x 2160 Ultra High Definition (UHD) screen with 30-point capacitive touch offers the kind of seamless user operation and rewarding experience that inspires confidence, trust, collaboration and effective decision making.



Pen-on-Paper

Hands-on collaborative working

With 4K reading and writing and intuitive Pen-on-Paper user experience, you can look forward to fantastic eyes-up group engagement with the PN-80TH5/PN-70TH5 BIG PADs.

Whether you're using a pen or your finger to make on-screen notes, the effect is so natural it quickly becomes intuitive. Our BIG PADs help you get the job done – it won't become a distraction. Not only will our BIG PADs help you create and deliver great presentations, but also gives the visible detail vital to specialists working in medical diagnostics, engineering, scientific and detailed design work.

Not only that, but the PN-80TH5/PN-70TH5 BIG PADs can emulate the Digital Imaging and Communications in Medicine (DICOM) standard for storing and transmitting medical images. The standard has been widely adopted by hospitals, and is making inroads into many dentists' and doctors' offices. The PN-80TH5/PN-70TH5 BIG PAD are not only ready to be used by medical professionals, but offer all the assurances needed by clinicians who need to review and trust the images they are working from.



SHARP Pen Software Interface

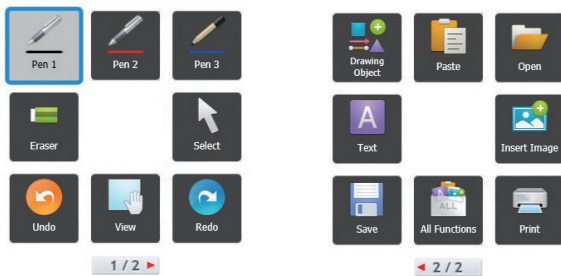

The PN-80TH5/PN-70TH5 come with standard Sharp Software to help make the most out of your interactive display. It's easy install and use, and doesn't require any technical expertise. These include SHARP Pen Software, Sharp Display Connect, SHARP Touch Viewing Software, Multi-Board feature and SHARP Downloader which offers overall support.

We know ease-of-use is important. But we understand being easy to use is only a great feature when it helps people become more productive. Our SHARP Pen software user interface has a menu of intuitive icons that make it simple for users, presenters and educators to access a range of useful functions. And not only can you overlay annotations or graphics directly onto photos, videos, PDFs, and common Microsoft® files, but you can store all these notes in USB memory, or email them to selected recipients.

With SHARP Touch Viewing Software you can manipulate a variety of different files on-screen without needing to open the respective applications. Your chosen files are displayed as 'sheets', which can be stored in onscreen virtual 'drawers'. This approach brings even more convenience and originality to business meetings, in-store installations, and more.

Flexibility and control

The four-button active pen that accompanies BIG PAD is designed to be as ergonomic as possible – easy to use and a great productivity tool too. Its 2mm tip, offering the Pen-on-Paper user experience, allows you to write on-screen in fine detail. Moving forwards and backwards through a slide deck is one example of the versatile functions the active pen buttons offer. Another simple button click can instantly trigger a menu of options, and another button can instantly trigger the erase mode, with the ability to easily erase mistakes and make changes - you've got the ideal blend of flexibility and control.



Fast, accurate and responsive to the lightest of touches, the 2mm pen is ideal when adding comments and annotations to detailed on-screen documents such as design reviews or microelectronics diagrams. It can even discriminate between false touch and intended one. So, you can rest your hand on the screen safely while making notes safe in the knowledge our palm-reject firmware won't let unintentional marks get in your way.

More flexibility. Greater control.

From where you use it, to how you use it – stay in control.

BIG PAD brings people together to work more effectively. Thanks to its quad-screen collaboration mode, four people can coordinate their work seamlessly in a split screen configuration, pulling in content from four independently connected sources. The additional screens can be connected via HDMI or DisplayPort connections or even via the Mini-OPS slot extension.

Inclusive and flexible

Multiple presenters, displaying information simultaneously makes for more inclusive planning and decision making. But it can also be invaluable in 24/7 mission critical environments. Key stakeholders can see content displayed as an overview on the four screens, or zoom into one screen with a simple menu operation. You can save vital seconds when crucial decisions need to be made.

When it comes to how and where you use your BIG PAD, you need flexibility. As well as wall mountings for meeting rooms and digital touch-signage, we allow a range of flexible installation possibilities, including face-up^{*1} in interactive tables. With our Peerless Mobile stand, you also have the opportunity to have your interactive display as a mobile solution; on wheels, allowing you to manoeuvre over various flooring surfaces and through doorways.^{**2}



Choosing our BIG PAD means you can create a stunning presentation, or have the capability to feature large datasets on connected BIG PADs side-by-side up to 4.6 meters in width, with Sharp's Advanced Multi-Board Capability. This looks great and works really well in, for example, a university lecture. BIG PAD's uniform flat front bezel and touchscreen surface brings all the connected content to the forefront of the presentation, lesson or meeting. With no undulations and a seamless surface, a more engaging user experience is ensured.



Direct Optical Bonding

The particularly smooth and special display construction also gives enhanced accuracy when annotating detailed and specialised content, such as marking up subtle imperfections on manufacturing quality control images.

The perceived close proximity of the glass touchscreen surface and the actual displayed content results in the best possible quality, contrast and visual performance.

This is important in a broad range of professional uses and specialised applications such as design work, engineering or science, where it is vital to have a consistent, accurate and natural touchscreen feeling when writing with either your finger or the 2mm Sharp pen.

Sharp achieves this thanks to Direct Optical Bonding, a technically demanding manufacturing process where the LCD panel is directly bonded to the touch glass layer with a transparent gel that sets after application. This ensures zero air gap between the LCD glass and the touchscreen glass, thereby minimising any parallax effect, internal reflection and refraction of light.

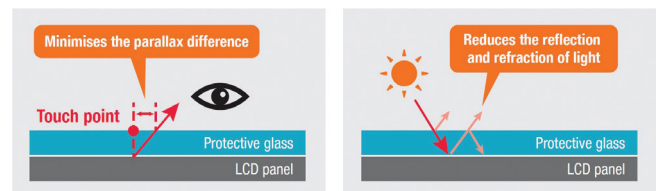

Capture and share ideas on the fly

With SHARP Display Connect any content, even handwritten notes, can be shared simultaneously wirelessly with up to 50 devices. This is especially useful for teachers and lecturers who want to share classroom materials, or set assignments.

Sharing and creating content is also made easy thanks to the Mini Open Pluggable Specification (Mini OPS) platform, which offers a wide range of compact, energy-efficient modules to enhance the way displayed content is managed. From interactive touch to non-touch professional displays, our Mini OPS platform is an attractive low-power and energy efficient option for display performance enhancement.

Not only does this mean great opportunities for innovative display and content, it also means Sharp's range of Mini OPS based displays are so much easier to live with and manage.

^{*1} The PN-80TH5 should not be mounted flat nor used as a touch table type installation. Please read specifications at the end for more detail.

^{**2} Peerless Mobile Stand L20PNSR780MEU.

Steve Keppler House Design Drawing (N

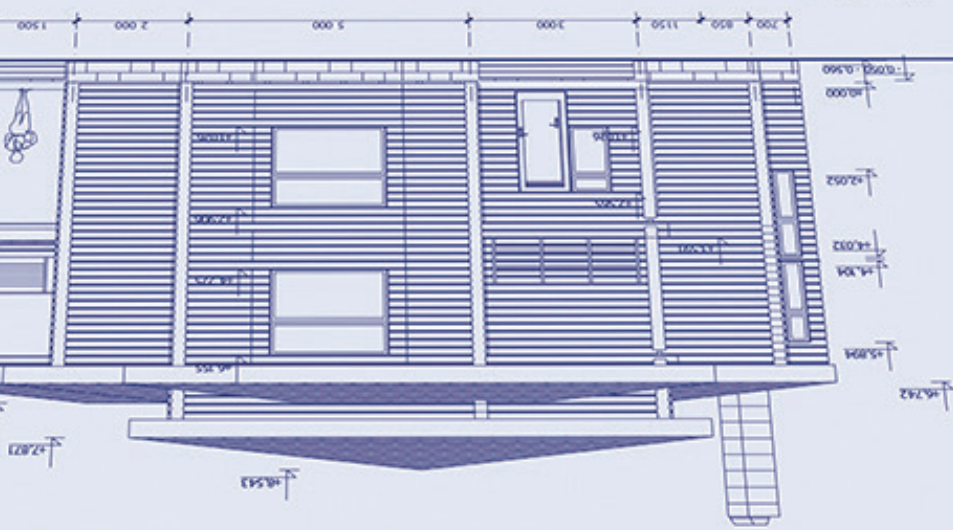

Elevation

Security

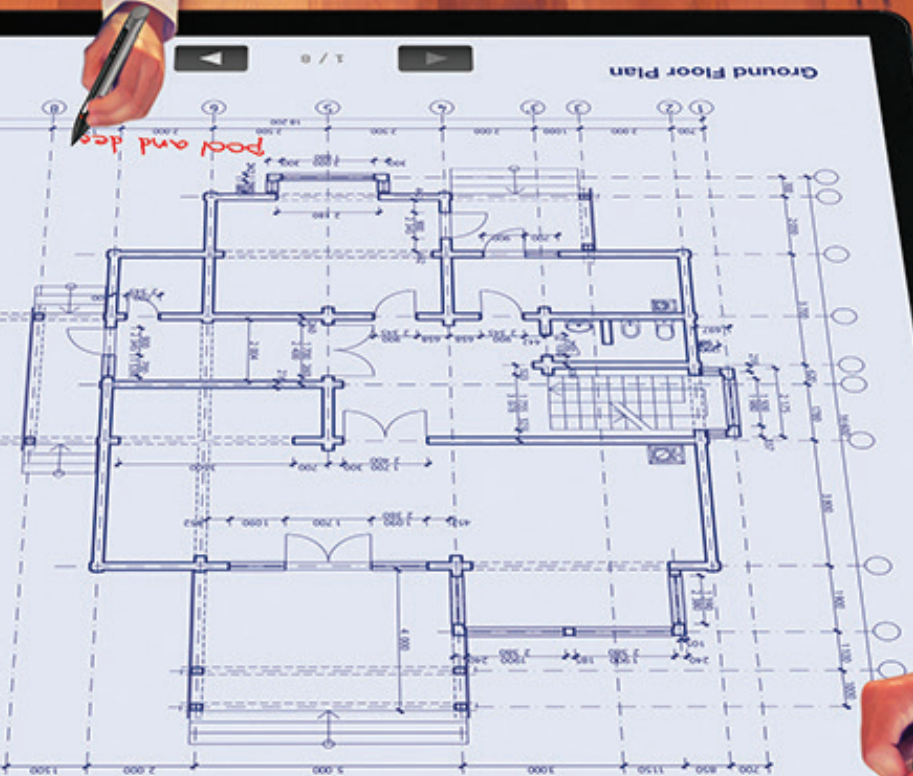

Ground Floor Plan

1 / 8

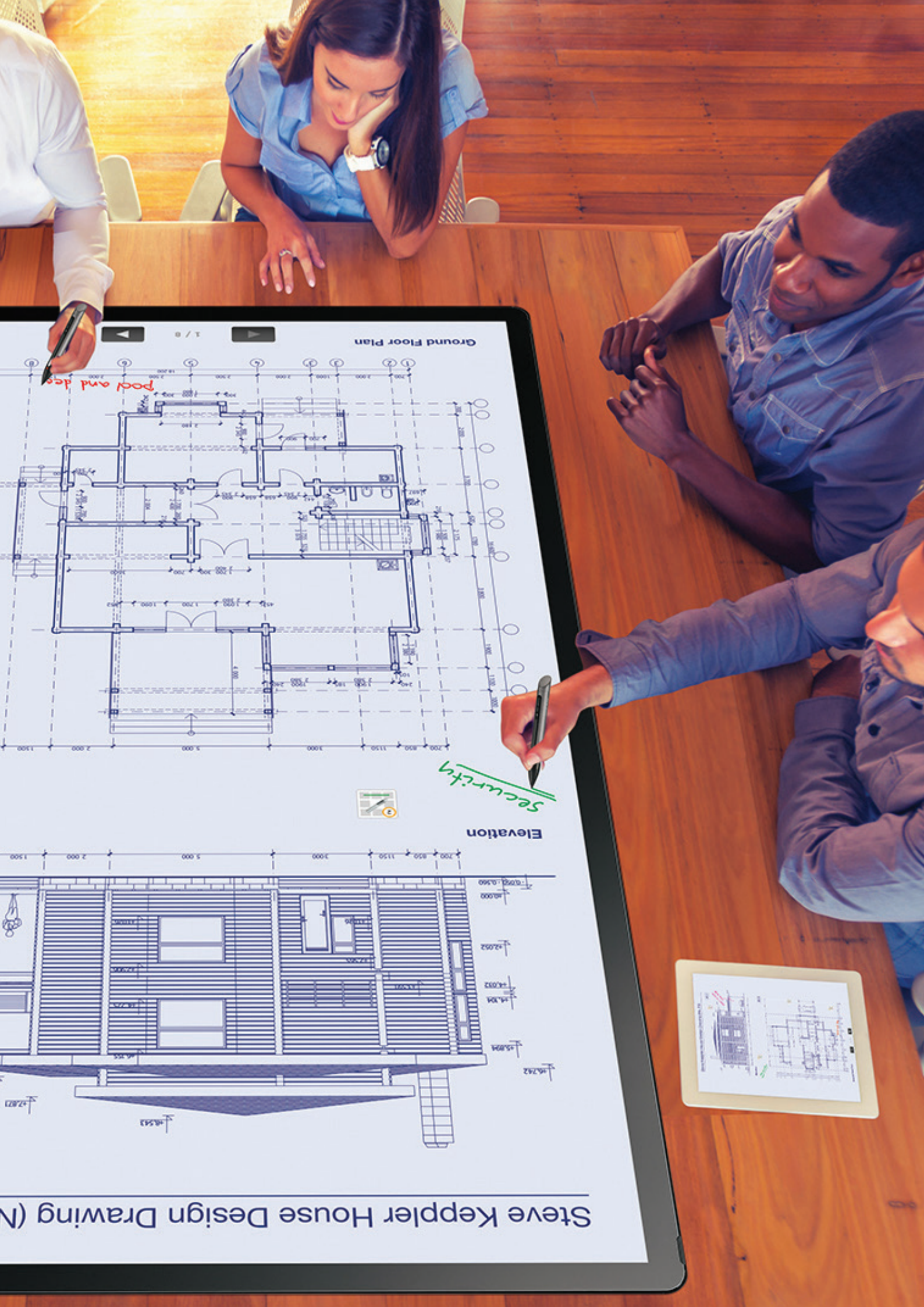



Welcome all device types

From where you use it, to how you use it – stay in control.

The optional PN-ZB03W wireless module allows up to 10 devices (including Mac or Windows computers, smartphones and tablets) to connect directly to your BIG PAD, making it completely at home in any bring your own device (BYOD) environment. This enables seamless co-working in a range of situations: radiology medics can share diagnostics imaging with peers; energy industry field operatives have freedom to share photos of sites, direct from their device, no matter whether they use Android or iOS.

No more trailing cables, no more bulky add-on peripherals, no more unsightly and problematic power supply issues. With Mini OPS on board, Sharp displays let you get on with creating the best possible visual impact, without being encumbered by unnecessary technology burdens.

Connect peripherals of your choice

Enjoy all the benefits of simple, tidy, cable-free PC integration, with a powerful single-board PC from the optional PN-ZB03PC module. It's a space-saving option perfect for teaching and meeting environments as it requires no additional space and runs quietly and reliably due to its fanless design. As well as high definition video output, there are two USB3.0 ports, allowing you to connect your choice of peripheral. And it includes support for Windows 10 IoT, giving specialist office professionals the ability to run Microsoft Office applications or other expert applications they need to make important decisions and recommendations.

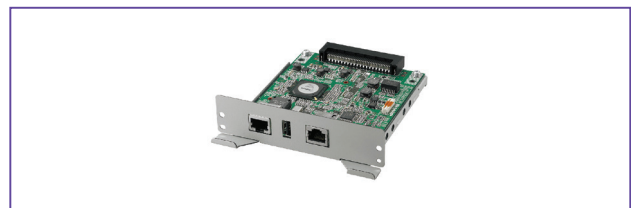

PN-ZB03H Mini OPS HDBaseT HDMI Receiver



PN-ZB03W Mini OPS Wireless



PN-ZB03PC Mini OPS PC

The stunning visuals and ground-breaking flexibility of the PN-80TH5/PN-70TH5 BIG PADs are further enhanced by the addition of integrated 10 + 10W speakers. Not only will this give great audio to give presentations, lessons, and seminars more impact, it does away with the need for external speaker systems, which in turn streamlines and simplifies set-up time. No additional or external equipment is required to playback videos with audio, reducing cost and allowing professionals to get started sooner. And there's no need to find, connect and test equipment prior to start.

Dimensions

(PN-80TH5)

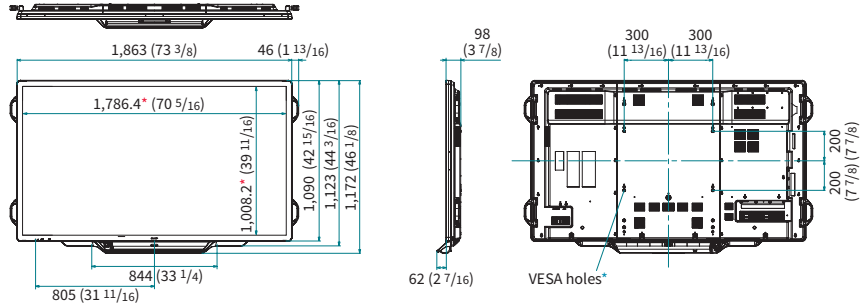

(PN-70TH5)

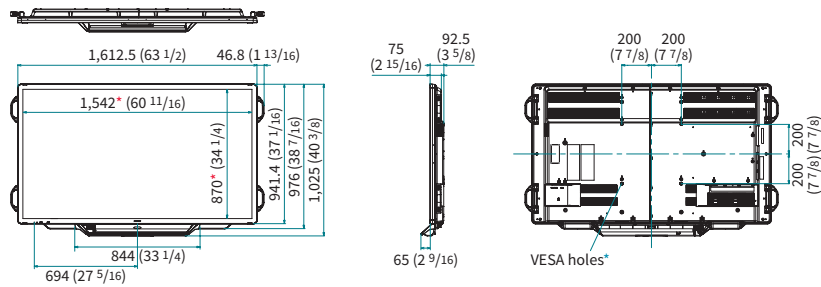

Units: mm (inch)

* Screen dimensions * To use the VESA-standard mounting bracket, use M6 screws that are 8 to 10 mm plus the thickness of the bracket.

Input/Output Terminals

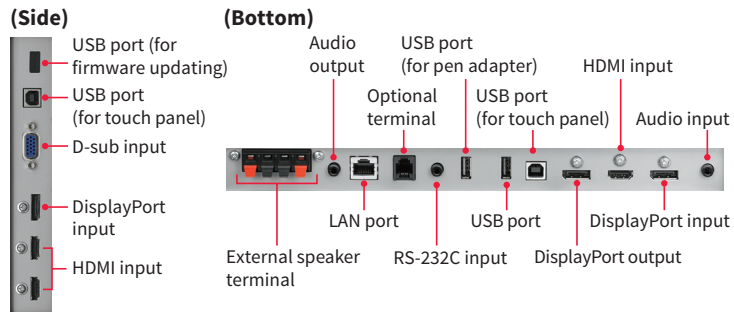

Option

- PN-ZL06 : Touch Pen
- PN-ZB03W : Wireless Board
- PN-ZB03H : HDBaseT Receiver Board
- PN-ZB03PC : Mini OPS PC

Specifications

General

Installation

PN-80TH5	Landscape / Portrait
PN-70TH5	Landscape / Portrait / Face-up

Warning: The PN-80TH5 should not be mounted flat nor used as a touch table type installation. Please consult an authorised SHARP dealer before considering any type of flat installation and find out about the mandatory flat mounting instructions.

Flat installation - when the monitor is tilted more than 20 degrees upward from the perpendicular in relation to a level surface.

LCD Panel

PN-80TH5	80-inch-class (293.2cm diagonal) UV ² A ¹ LCD
PN-70TH5	70-inch-class (176.6 cm diagonal) UV ² A ¹ LCD

Max. Resolution 3,840 x 2,160 pixels

Max. Display Colours (approx.) 1.06 billion colours

Pixel Pitch (H x V)

PN-80TH5	0.462 x 0.462 mm
PN-70TH5	0.401 x 0.401 mm

Max. Brightness (average)² 300 cd/m²

Contrast Ratio 4,000 : 1

Viewing Angle (H/V) 176°/176° (CR >10)

Active Screen Area (W x H)

PN-80TH5	1,771.2 x 996.3 mm
PN-70TH5	1,538.9 x 865.6 mm

Response Time 6 ms (grey to grey, avg.)

Backlight

PN-80TH5	LED, full array
PN-70TH5	LED, edge lit

Touchscreen

Touch Technology Projected Capacitive (P-CAP) touch

PC Connection Port USB (2.0 compliant) (Type B) x 2

Power Supply Supplied from main unit

Multi Touch 30 points

Protection Glass Thickness: approx. 1.9 mm³ Shock resistance: 130 cm⁴

Touch Pen

Communication Wireless communication method

Function Button Yes

Computer Input

Video	Analogue RGB (0.7 Vp-p) [75Ω], HDMI, DisplayPort™ 1.2a
Synchronisation	Horizontal/vertical separation (TTL: positive/negative), Sync on green ⁵ , Composite sync (TTL: positive/negative) ⁵
Plug & Play	VESA DDC2B
Power Management	VESA DPMS
Video Colour System	TSC (3.58 MHz) / NTSC (4.43 MHz) / PAL / PAL60 / SECAM
Input Terminals	PC analogue: Mini D-sub 15-pin x 1 ⁶ , HDMI (HDCP compatible, PC/AV signal compatible) x 3, 3.5 mm-diameter mini stereo jack x 1, Component video x 1 ⁷ , DisplayPort (HDCP compatible) x 2, RS-232 x 1
Output Terminals	3.5 mm-diameter mini stereo jack x 1, DisplayPort (HDCP compatible) x 1
Input/Output Terminals	LAN port (10Base-T/100Base-TX) x 1
USB Hub Function	USB 2.0 (Type A) x 2
Expansion Slot	13 V, 2.4 A (power supplied when expanding the functions with an optional part)
Speaker Output	10 W + 10 W
Mounting	VESA (4 points), 400 x 200 mm pitch, M6 screw
Power Supply	100 V – 240 V AC, 50/60 Hz ⁵
Power Consumption	
PN-80TH5	325 W
PN-70TH5	215 W
Environmental Conditions	
Operating Temperature ^{8,9}	5 °C to 35 °C
Operating Humidity ⁹	20% to 80% RH (no condensation)
Dimensions (W x D x H) (approx.) (display only)	
PN-70TH5	1,612.5 x 92.5 x 941.4 mm
PN-80TH5	1,863 x 98 x 1,090 mm
Weight (approx.)	
PN-70TH5	57kg
PN-80TH5	73kg
Main Accessories	AC power cord, remote control unit, remote control unit battery (AAA size) x 2, set-up manual, cable clamp (insertion type) x 4, cable clamp x 3, USB cable, USB extension cable, RS-232C conversion cable, eraser, pen tray, touch pen, touch pen adapter, touch pen adapter screw, touch pen battery (AAA size), pen tip x 2, speaker cover x 2, camera mount, camera screw, speaker cover attachment screw/camera mount screw x 6, CD-ROM, SHARP Display Connect license, vertical sticker, blank sticker



¹UV²A stands for Ultraviolet-induced Multi-domain Vertical Alignment, a photo-alignment technology that ensures uniform alignment of liquid crystal molecules. ²Brightness depends on input mode and other picture settings. Brightness level will decrease slightly over the lifetime of the product. Due to the physical limitations of the equipment, it is not possible to maintain a precisely constant level of brightness. ³Including AG film on the front. ⁴Approximate distance at which the glass panel can withstand the impact of a 500-gram iron ball dropped on its centre. ⁵D-sub input terminal only. ⁶When connecting with an analogue mini D-sub 15-pin jack, max. resolution is 1,920 x 1,200 pixels. ⁷Analogue PC, video, and component video are switchable (on bottom interface); use the menu to select. Video and component video connections require conversion cable via mini D-sub 15-pin jack. ⁸When using the monitor laying flat on a surface (when the monitor is tilted more than 20 degrees upward from the perpendicular in relation to a level surface) the ambient temperature must be within the range of 5°C to 30°C. Temperature conditions may change when using the monitor together with the optional equipment. In such cases, check the temperature conditions specified by the optional equipment. ⁹Check the requirements of the computer and other devices to be connected, and make sure that all requirements are satisfied. Microsoft PowerPoint, Excel, Windows, OneNote, and Outlook are either registered trademarks or trademarks of Microsoft Corporation in the US and/or other countries. DisplayPort and the DisplayPort Compliance Logo are trademarks owned by the Video Electronics Standards Association in the US and other countries. The terms HDMI and High-Definition Multimedia Interface and the HDMI logo are trademarks or registered trademarks of HDMI Licensing, LLC in the US and other countries. Intel, Intel Core, and Celeron are trademarks of Intel Corporation in the US and/or other countries. Sempron and Athlon are trademarks of Advanced Micro Devices, Inc. Adobe, Illustrator, and Photoshop, are either registered trademarks or trademarks of Adobe Systems Incorporated in the United States and/or other countries. Apple, iPhone, iPad, Mac, and OS X are trademarks of Apple Inc., registered in the US and other countries. Android and Google Play are trademarks of Google Inc. App Store is a service mark of Apple Inc. iOS is a trademark or registered trademark of Cisco in the US and other countries and is used under license. All other brand names and product names may be trademarks or registered trademarks of their respective owners. DESIGN AND SPECIFICATIONS ARE SUBJECT TO CHANGE WITHOUT PRIOR NOTICE. PN-80TH5/PN-70TH5 Brochure. May 2018. Job No. 19152. All trademarks acknowledged E&OE.